

Sollevatori con pedane piane  
Lifts with flat platforms  
Hebebühnen mit flachen Fahrschienen  
Élévateurs avec chemins de roulement plats  
Elevadores con plataformas lisas

# 1

SF 6350 / 3500 kg  
SF 6400 / 4200 kg  
SF 6500 / 5000 kg  
SF 6600 / 6000 kg

Sollevatori con pedane di grandi dimensioni e struttura portante studiata per la massima rigidità e stabilità in esercizio.

Lifts with large size platforms and sturdy structure assuring maximum rigidity and working stability.

Hebebühnen mit grossdimensionierten Fahrschienen und für hervorragende Steifigkeit und Betriebsstabilität konstruierte Tragstruktur.

Ponts élévateurs avec chemins de roulement de grandes dimensions et structure portante étudiée pour offrir un maximum de rigidité et de stabilité pendant le fonctionnement.

Elevadores con plataformas de grandes dimensiones y estructura portante estudiada para garantizar la máxima rigidez y estabilidad de trabajo.

PLATFORMS **4600 x 615 mm**  
**5500 x 650 mm New**



Dispositivo di appoggio meccanico ad inserimento automatico e disinserimento pneumatico, a garanzia della massima sicurezza in fase di stazionamento.

Mechanical locking device with automatic engagement and pneumatic release, ensuring maximum safety when lift is in standing position.

Mechanische Stützvorrichtung mit automatischer Einschaltung und pneumatischer Ausschaltung, um eine maximale Sicherheit im aufgehobenen Zustand zu garantieren.

Dispositif de soutien mécanique avec enclenchement automatique et dégageur pneumatique, pour garantir la sécurité totale pendant le stationnement.

Dispositivo de apoyo mecánico de funcionamiento automático y desbloqueo neumático, como garantía de la máxima seguridad en la fase de estacionamiento.

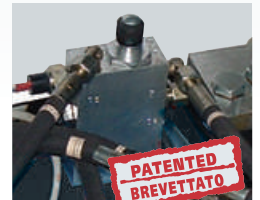

Sincronizzazione idraulica dei movimenti delle pedane indipendentemente dalla ripartizione del carico.

Hydraulic levelling system by means of a patented synchronisation device assures constantly level lifting platforms regardless of weight distribution.

Hydraulische Gleichlaufregelung der beiden Fahrschienen, unabhängig von der Lastverteilung.

Synchronisation hydraulique des plateaux indépendante de la distribution de la charge.

Sincronización hidráulica de las plataformas independientemente del reparto de carga.

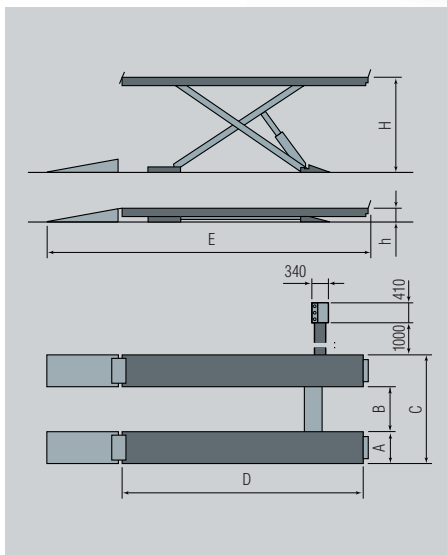

	Portata Traffigkeit Capacité Capacity Capacidad	Motore Motor Moteur Motor Motor	A	B	C	D	E	h	H
SF 6351	3500	2,6	615	870	2100	4600	6110	265	1850
SF 6351I							x		2085
SF 6351LT		3,5					6130	295	1880
SF 6351ILT							x		2115
SF 6401	4200	2,6	615	870	2100	4600	6110	265	1850
SF 6401I							x		2085
SF 6401LT		3,5					6130	295	1880
SF 6401ILT							x		2115
SF 6501.55	5000	2,6	650	900	2200	5500	7015	265	1850
SF 6501.55I							x		2070
SF 6501.55LT		3,5					7015	295	1880
SF 6501.55ILT							x		2100
SF 6601.55	6000	2,6	650	900	2200	5500	7015	270	1850
SF 6601.55I							x		2070
SF 6601.55LT		3,5					7015	300	1880
SF 6601.55ILT							x		2100

## SF SERIES

Sollevatori elettroidraulici a forbice

(IT)

Electro-hydraulic scissor lifts

(EN)

Elektrohydraulische Scherenhebebühnen

(DE)

Elevateurs electro-hydrauliques à ciseaux

(FR)

Elevadores electrohidraulicos de tijera

(ES)

Sollevatori per misurazione assetto ruote  
*Wheel alignment lifts*  
 Hebebühnen für die Achsvermessung  
 Elévateurs pour contrôle de géométrie  
 Elevadores alineado de direccion

2

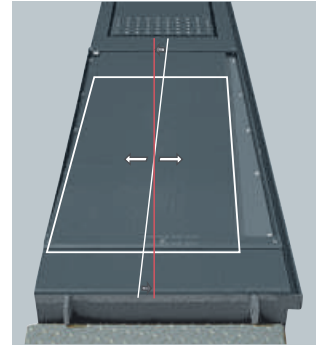

Piattaforme oscillanti con bloccaggio pneumatico in posizione centrata e movimenti di oscillazione angolare e trasversale in entrambe le direzioni.

*Rear slip plates with pneumatic locking in true position, angular and transversal movements in both directions.*

Schiebeplatten mit pneumatischer Arretierung in zentrierter Position sowie Winkel- und Querverschiebung in beiden Richtungen.

*Plaques de débattement avec blocage pneumatique en position centrale. Mouvement des plaques longitudinal et transversal.*

Platos oscilantes con bloqueo neumático en posición centrada y movimientos de oscilación angular y trasversal en ambas direcciones.

Pedane per assetto totale, con sedi anteriori per piatti rotanti e piani oscillanti posteriori.

*Platforms for total wheel alignment, with front turning plates locations and rear slip plates.*

Fahrschienen für die gesamte Achsvermessung, vorne mit Sitzen für Drehteller und hinten mit Schiebeplatten.

*Chemins de roulement pour géométrie totale, avec logements avant pour plateaux pivotants et plans mobiles arrière.*

Plataformas para alineación total, con asientos para platos giratorios delanteros y platos oscilantes traseros.



Perni di articolazione con boccole autolubrificanti non richiedenti manutenzione.

*All pivot points made with self lubricating bushings for long life.*

Gelenkbolzen mit selbstschmierenden Büchsen die keiner Wartung bedürfen.

*Pivots d'articulation avec bagues autolubrifiantes, ne nécessitant pas d'entretien.*

Pernos de articulación con casquillos autolubricantes que no requieren mantenimiento alguno.



Basi con dispositivi di livellamento.  
*Base plates with levelling system.*

Grundrahmen mit Nivellier Vorrichtungen.

*Bases avec dispositifs de nivellement.*

Bases al suelo con dispositivo de nivelación.

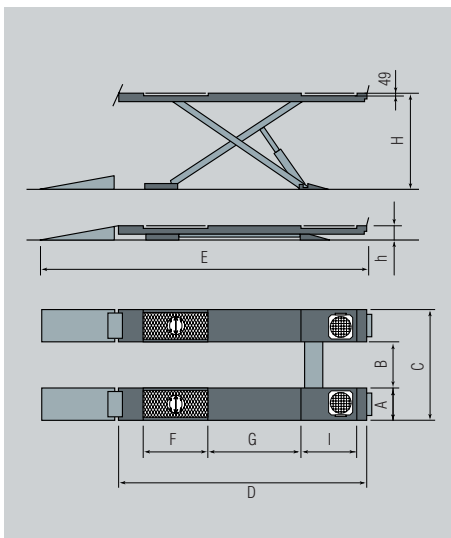

	Portata	Motore	A	B	C	D	E	F	G	I	h	H
	Traffigkeit	Motor										
	Capacité	Moteur	mm	mm	mm	mm	mm	mm	mm	mm	mm	mm
	Capacidad	Motor										
SF 6352	3500	2,6	615	870	2100	4600	6110	1740	1764	825	265	1850
SF 6352I							x					2085
SF 6352LT		6130					295					1880
SF 6352ILT		x					2115					
SF 6402	4200	2,6	615	870	2100	4600	6110	1740	1764	825	265	1850
SF 6402I							x					2085
SF 6402LT		6130					295					1880
SF 6402ILT		x					2115					
SF 6502.55	5000	2,6	650	900	2200	5500	7015	1780	1745	1525	265	1850
SF 6502.55I							x					2070
SF 6502.55LT		7015					295					1880
SF 6502.55ILT		x					2100					
SF 6602.55	6000	2,6	650	900	2200	5500	7015	1780	1745	1525	270	1850
SF 6602.55I							x					2070
SF 6602.55LT		7015					300					1880
SF 6602.55ILT		x					2100					



**Sollevatori con provagiochi**  
*Lifts with built in play detector*  
 Hebebühnen mit Gelenkspieltestern  
*Élévateurs avec plaques à jeux*  
 Elevadores con detector de holguras

**4 6**



Motor 2,6 kW

Provagiochi a 4 movimenti  
*4 movement play detector*  
 4 Bewegungen Gelenkspieltester  
*Plaques à jeux à 4 mouvements*  
 Detector de holguras de 4 movimientos



Provagiochi a 8+4 movimenti  
*8+4 movement play detector*  
 8+4 Bewegungen Gelenkspieltester  
*Plaques à jeux à 8+4 mouvements*  
 Detector de holguras de 8+4 movimientos

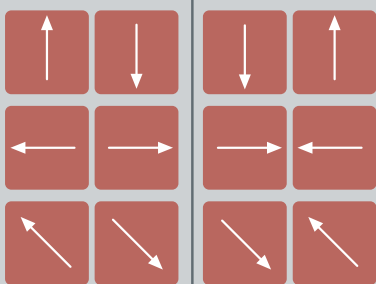

	Portata Capacity Traffigkeit Capacité Capacidad	mm						
		A	B	D	E	F	h	H
SF 6354	3500	4600	6110	615	870	2100	265	1850
SF 6354I			x					2085
SF 6354LT			6130					1880
SF 6354ILT			x					2115
SF 6404.46	4200	4600	6110	615	870	2100	265	1850
SF 6404.46I			x					2085
SF 6404.46LT			6130					1880
SF 6404.46ILT			x					2115
SF 6406.55	4200	5500	7015	650	900	2200	265	1850
SF 6406.55I			x					2070
SF 6406.55LT			7015					1880
SF 6406.55ILT			x					2100
SF 6506.55	5000	5500	7015	650	900	2200	265	1850
SF 6506.55I			x					2070
SF 6506.55LT			7015					1880
SF 6506.55ILT			x					2100
SF 6606.55	6000	5500	7015	650	900	2200	270	1850
SF 6606.55I			x					2070
SF 6606.55LT			7015					1880
SF 6606.55ILT			x					2100

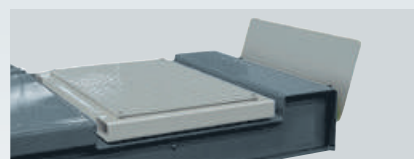
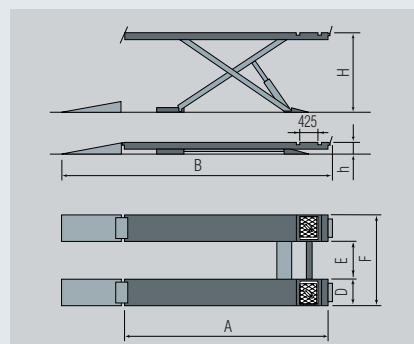

Piastre con superficie bugnata per evitare lo slittamento piastra-ruota.

*Plate with indented surface to prevent plate-wheel sliding.*

Platten mit Bossenoberfläche um das Platte-Rad-Rutschen zu vermeiden.

*Plaques avec surface bosselée pour empêcher le glissement des roues.*

Placas con superficie almohadillada para evitar deslizamiento de placa-rueda.



**Sollevatori per allineamento con provagiochi**  
*Alignment lifts with built in play detector*  
 Achsmessbühnen mit Gelenkspieltestern  
*Élévateurs pour géométrie avec plaques à jeux*  
 Elevadores para alineado con detector de holguras

**3 5**

Motor 2,6 kW



Provagiochi a 4 movimenti  
*4 movement play detector*  
 4 Bewegungen Gelenkspieltester  
*Plaques à jeux à 4 mouvements*  
 Detector de holguras de 4 movimientos



Provagiochi a 8+4 movimenti  
*8+4 movement play detector*  
 8+4 Bewegungen Gelenkspieltester  
*Plaques à jeux à 8+4 mouvements*  
 Detector de holguras de 8+4 movimientos

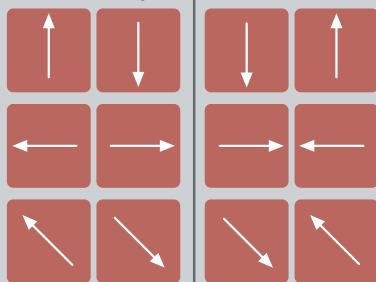

	Portata Capacity Traffigkeit Capacité Capacidad	mm									
		A	B	C	D	E	F	G	I	h	H
SF 6403.46	4200	4600	6110	1280	615	870	2100	1764	900	265	1850
SF 6403.46I			x								2085
SF 6403.46LT			6130								1880
SF 6403.46ILT			x								2115
SF 6405.55	4200	5500	7015	1780	650	900	2200	1745	1525	265	1850
SF 6405.55I			x								2070
SF 6405.55LT			7015								1880
SF 6405.55ILT			x								2100
SF 6505.55	5000	5500	7015	1780	650	900	2200	1745	1525	265	1850
SF 6505.55I			x								2070
SF 6505.55LT			7015								1880
SF 6505.55ILT			x								2100
SF 6605.55	6000	5500	7015	1780	650	900	2200	1745	1525	270	1850
SF 6605.55I			x								2070
SF 6605.55LT			7015								1880
SF 6605.55ILT			x								2100

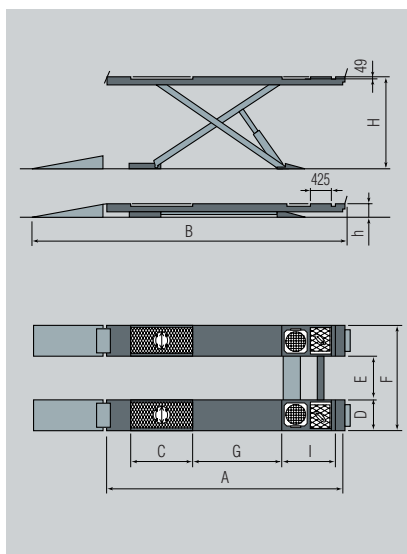



Versioni incassate  
Recessed versions  
Unterflurausführungen  
Versions à encastrement  
Versiones empotradas



Versioni con sollevatore integrato  
Versions with wheel free lift  
Versionen mit integriertem Radfreiheber  
Versions avec élévateur intégré  
Versiones con elevador auxiliar



	kg	A mm	B mm
SF 6350I	3500	1805	2085
SF 6350ILT			2115
SF 6400I	4200	1805	2085
SF 6400ILT			2115
SF 6500I	5000	1805	2070
SF 6500ILT			2100
SF 6600I	6000	1805	2070
SF 6600ILT			2100

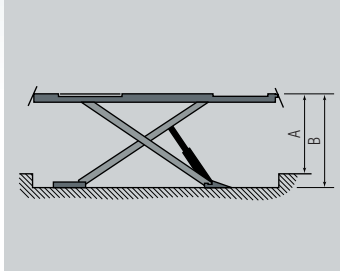

	Portata Traffigkeit Capacité Capacity Capacidad	A mm	B mm	C mm
SF 6350LT	3500	2000	1390	500
SF 6400LT				500
SF 6400.55LT	4000	2100	1390	490
SF 6500.55LT				490
SF 6600.55LT				490

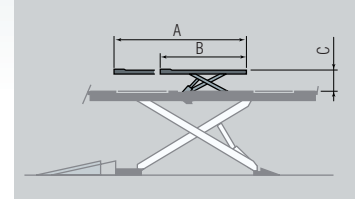

## OPTIONS

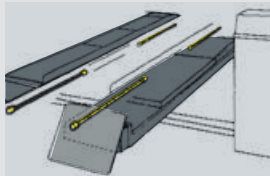

**VAR S 650 A7**  
Impianto di illuminazione  
*Lighting kit*  
Beleuchtung  
*Système d'éclairage*  
Instalación de alumbrado



**S650LA1**  
**S640A1**  
**S650A1**  
Spessori di riempimento per  
sedi piatti rotanti  
*Spacers for turn table housing*  
Distanzstücke für  
Drehtelleraussparungen  
*Cales longitudinales pour*  
*plateaux pivotants*  
Espesores para huecos platos  
rotatorios



**S 611 A4**  
Carter centralina  
*Power unit cover*  
Schaltkastenabdeckung  
*Couverture pupitre*  
Protección centralita



Traverse  
*Jacking beams*  
Achsheber  
*Traverses*  
Gatos



Comando a distanza  
per tutti i modelli.  
*Remote control hand*  
*set for all models.*  
Kabelfernsteuerung  
für alle Ausführungen.  
*Commande à distance*  
Mando a distancia



**S 110 A7 (2 x kit)**  
Piatti rotanti per assetto.  
*Turntables for wheel*  
*alignment.*  
Drehteller für  
Achsvermessung.  
*Plateaux pivotants pour*  
*contrôle de la géométrie*  
*(2 pièces).*  
Platos giratorios para  
alineación (2 pzas).

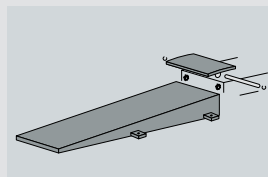

**S 601A4**  
Rampe lunghe  
(L= 1900mm)  
*Longer run-up ramps*  
(L= 1900mm)  
Längere Auffahrrampen  
(L= 1900mm)  
*Rampes d'accès longues*  
(L= 1900mm)  
Rampas de subida largas  
(L= 1900mm)

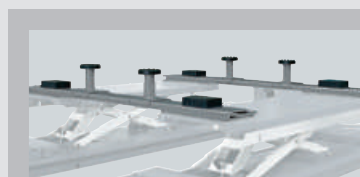

Set tamponi  
*Set of pads*  
Satz Klötze  
*Tampons*  
Juego de tacos  
(4 x kit)



**S 505 A1**  
H = 200 mm

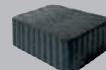

**S 505 A5**  
H = 120 mm

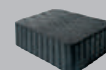

**S 505 A9**  
H = 60 mm



**S 505 A6**  
H = 40 mm

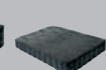

**S 505 A7**  
H = 20 mm

### OPTIONS LT

**S 505 A2 (2 x kit)**  
Traverse per veicoli particolari  
*Cross members for special vehicles*  
Querstreben  
*Traverses pour véhicules spéciaux.*  
Traviesas para vehículos especiales.

**SPACE s.r.l. a s.u.**

Via Sangano, 48  
10090 Trana - Torino - ITALY  
tel. +39-011-934.40.300  
fax +39-011-933.88.64  
e-mail: info@spacetest.com  
www.spacetest.com

Le caratteristiche tecniche e gli allestimenti presentati in questo prospetto possono subire variazioni. Le immagini riprodotte non sono vincolanti.  
*Technical data and composition presented in this catalogue may vary. Pictures reproduced are only indicative.*  
Die techn. Daten und die Ausrüstungen, die in diesem Prospekt enthalten sind, können Änderungen erfahren. Deshalb sind die Abbildungen unverbindlich.  
*Les caractéristiques techniques et les compositions présentées dans ce prospectus peuvent subir des variations. Les images reproduites n'ont qu'une valeur indicative.*  
Las características técnicas y las composiciones ilustradas en este folleto pueden sufrir variaciones. Las imágenes propuestas son solamente indicativas.

