



**SQ 350 / 3500 kg (4300 mm)**  
**SQ 401 / 4000 kg (4460 mm)**  
**SQ 405L / 4000 kg (5100 mm)**  
**SQ 501L / 5000 kg (5700 mm)**

SQ 350

- Cilindro idraulico inserito all'interno della pedana fissa e quindi completamente protetto
- Funi di sollevamento ad alta resistenza, zincate e prestirate
- Puleggie di grande diametro con boccole autolubrificanti esenti da manutenzione
- Dispositivi di appoggio meccanico (ogni 100mm di corsa) ad inserimento automatico e sblocco pneumatico per lavorare in condizioni di stazionamento a funi scariche
- Dispositivi di sicurezza meccanici, elettrici ed idraulici conformi alla normativa vigente relativa alla marcatura CE
- *The hydraulic cylinder is located inside the fixed platform and is thus perfectly protected*
- *High-resistant, galvanised and pre-stretched metal cables*
- *Large-diameter pulleys with self-lubricating and maintenance-free bushes*
- *Automatic mechanical back-up safety devices (every 100 mm) with pneumatic release allowing stationary operation with unladen cables*
- *Mechanical, electrical and hydraulic safety devices in compliance with the prevailing standard for CE marking*
- Hydraulischer, in der festliegenden Fahrtschiene angeordneter und so vollkommen geschützter Zylinder.
- Hochwiderstandsfähige, verzinkte und vorgezogene Hebeeseile.
- Riemenscheiben mit großem Durchmesser mit selbstschmierenden und wartungsfreien Buchsen.
- Mechanische Auflagevorrichtungen (alle 100 mm im Hublauf) mit automatischer Einrastung und pneumatischer Auslösung ermöglichen ein Arbeiten im stationären Zustand bei entlasteten Seilen.
- Mechanische, elektrische und hydraulischer Sicherheitsvorrichtungen, die den gültigen Richtlinien im Bezug auf den Erhalt des CE-Zeichens entsprechen.
- *Vérin hydraulique à l'intérieur du chemin de roulement fixe et donc entièrement protégé*
- *Câbles de levage à haute résistance, galvanisés et pré-étirés*
- *Poulies de grand diamètre avec douilles autolubrifiantes sans entretien*
- *Dispositifs d'appui mécanique (tous les 100 mm) à enclenchement automatique et déblocage pneumatique pour travailler en conditions de stationnement avec câbles déchargés*
- *Dispositifs de sécurité mécaniques, électriques et hydrauliques conformes à la norme CE*
- Cilindro hidráulico montado dentro de la plataforma fija, por lo tanto completamente protegido
- Cables de elevación de alta resistencia, galvanizados y pre-estirados
- Poleas de gran diámetro con casquillos autolubrificantes que no requieren mantenimiento
- Dispositivos de apoyo mecánico (cada 100 mm de carrera) con conexión automática y desbloqueo neumático para trabajar en condiciones de estacionamiento y con los cables sin carga
- Dispositivos de seguridad mecánicos, eléctricos e hidráulicos conformes a la norma CE

## SQ SERIES

**Sollevatori elettroidraulici a 4 colonne**

(IT)

**Electrohydraulic 4-post lifts**

(EN)

**Elektrohydraulische 4-Säulen-Hebebühnen**

(DE)

**Élévateurs électro-hydrauliques 4 colonnes**

(FR)

**Elevadores electrohidráulicos de 4 columnas**

(ES)



	SQ 350	SQ 401	SQ 405L	SQ 501L
A	400	500	650	650
C max	1170	1250	900	940
C min	850	910	900	776
D	2120	2470	2670	2645
E	mm 2450	2800	3000	3000
F	2805	3155	3355	3355
G			2614	
H max		1905		1915
H min		150		160
L	4300	4460	5100	5700
M	5029	5418	6097	6707

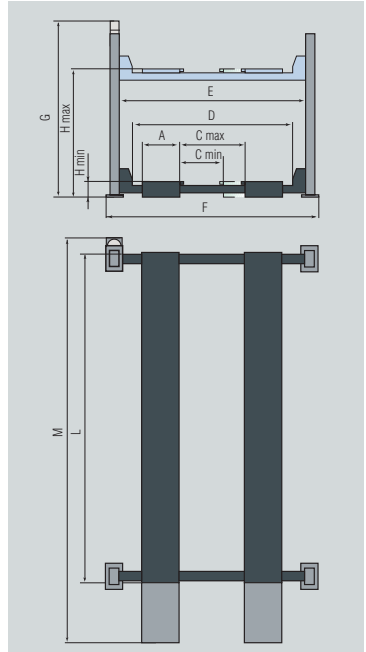

**SQ 651L / 6500 kg (5700 mm)**  
**SQ 800 / 8000 kg (6000 mm)**

Grande apertura fra le colonne per il passaggio di veicoli larghi. Portate e dimensioni ideali per furgoni e autocarri leggeri.

*Large clearance between posts to allow loading of wide vehicles. Ideal capacities and sizes for vans and medium duty trucks.*

Der erhebliche innere Abstand der Säulen ermöglicht eine gute Beladungsfähigkeit auch mit breiten Fahrzeugen. Tragfähigkeiten und Maßen für Lieferwagen und LLKW's.

*Distance considérable entre colonnes pour permettre le chargement de véhicules larges. Portées et dimensions idéales pour fourgons et camions légers.*

La grande distancia entre las columnas permite cargar vehiculos comerciales muy largos. Capacidades y dimensiones ideales para furgonetas y camiones ligeros.

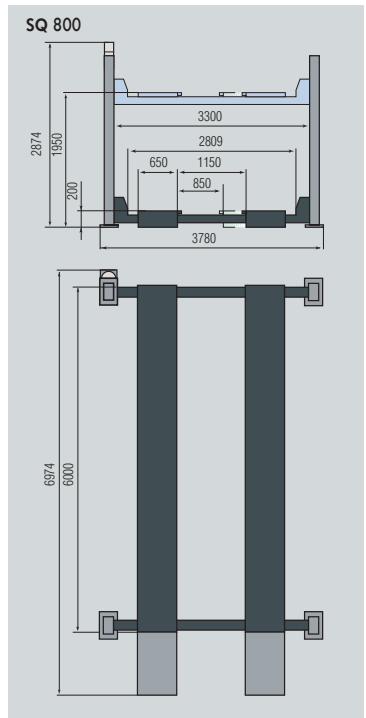
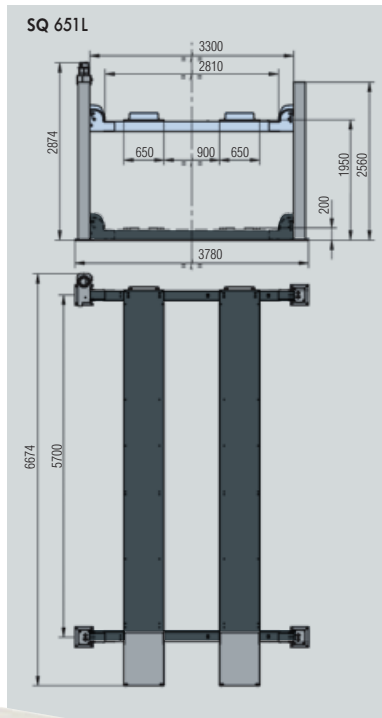



**SQ 402 / 4000 kg (4460 mm)**  
**SQ 406L / 4000 kg (5100 mm)**  
**SQ 502L / 5000 kg (5700 mm)**  
**SQ 652L / 6500 kg (5700 mm)**  
**SQ 802 / 8000 kg (6000 mm)**

Pedane per assetto totale, con sedi anteriori per piatti rotanti e piani oscillanti posteriori.

*Platforms for total wheel alignment, with front turning plates locations and rear slip plates.*

Fahrschienen für die gesamte Achsvermessung, vorne mit Sitzen für Drehteller und hinten mit Schiebepplatten.

*Chemins de roulement pour géométrie totale, avec logements avant pour plateaux pivotants et plans mobiles arrière.*

Plataformas para alineación total, con asientos para platos giratorios delanteros y platos oscilantes traseros.



## OPTIONS

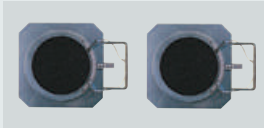

**S110A7**  
 Piatti rotanti.  
*Turntables.*  
 Drehplatten.  
*Plateaux pivotants.*  
 Platos giratorios.



Rampe extralungue  
*Long run up ramps*  
 Lange Auffahrampen  
*Rampes longues*  
 Rampas largas

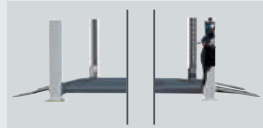

Rampe di discesa  
*Run off ramps*  
 Abfahrampen  
*Rampes descente*  
 Rampas de bajada

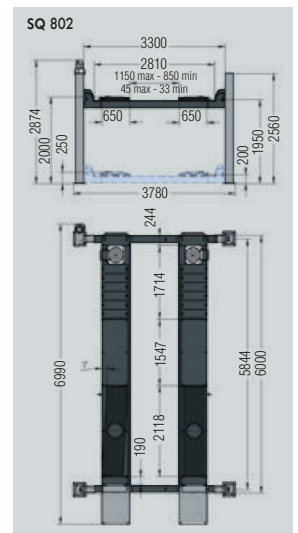
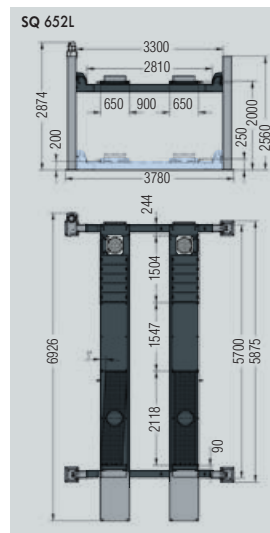
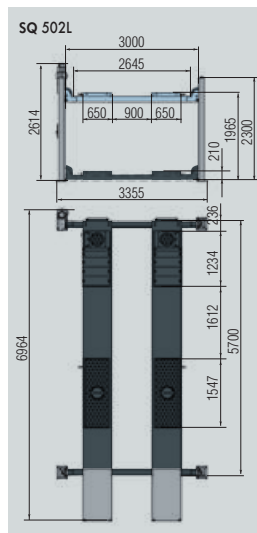
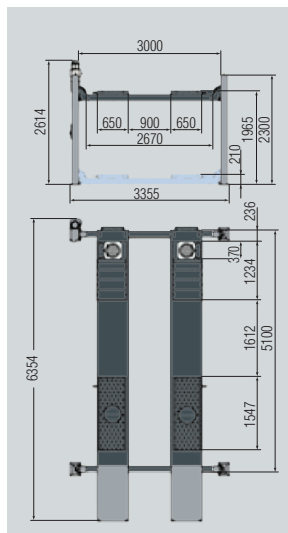
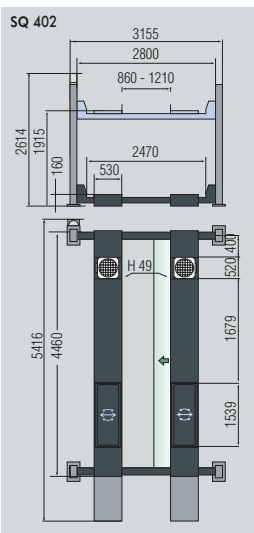
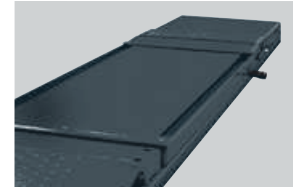
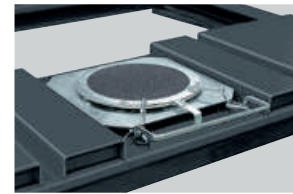





### Service Lift

SQ 401LT / 4000 kg (4460 mm)

SQ 405ELT / 4000 kg (5100 mm)

### Wheel Alignment Lift

SQ 402LT / 4000 kg (4460 mm)

SQ 406LLT / 4000 kg (5100 mm)

SQ 502LLT / 5000 kg (5700 mm)

	401LT	405ELT
A max	1210	1260
A min	860	865
B	2470	2670
C	2800	3000
D	3155	3355

SQ401LT	3500 kg
SQ405ELT	
SQ402LT	
SQ406LLT	
SQ502LLT	4000 kg



SQ 401LT - SQ 405ELT

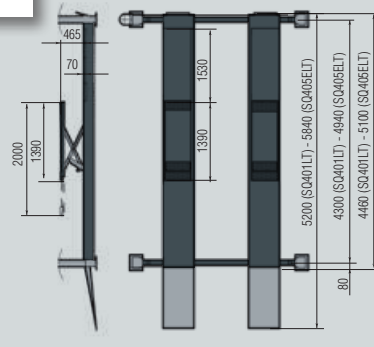
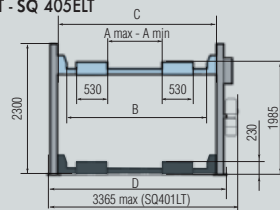

SQ 402LT

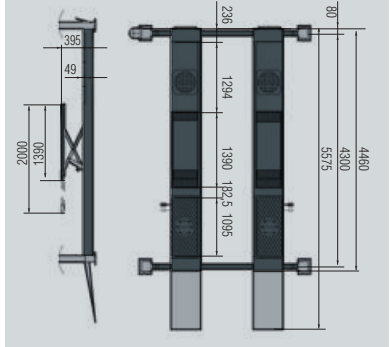
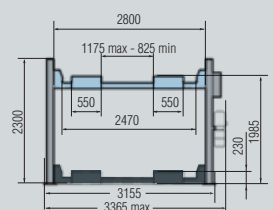

### OPTIONS



S505A2 (2 x kit)

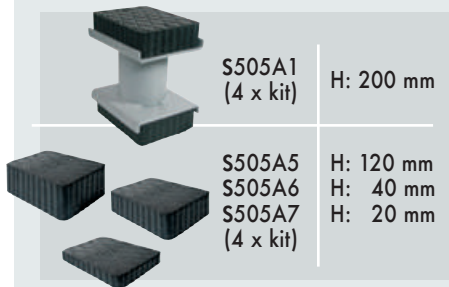

SQ 406LLT

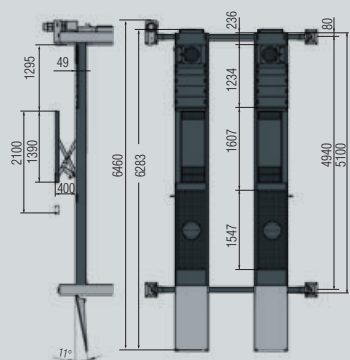
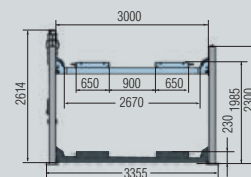

SQ 502LLT

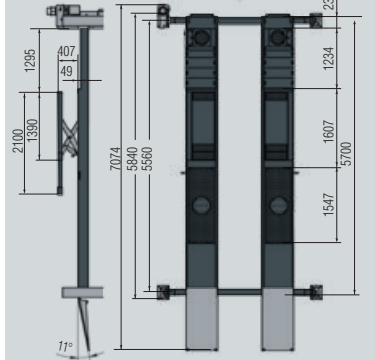
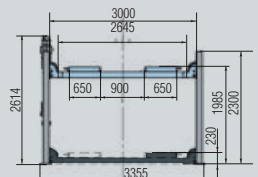

## SPACE s.r.l. a s.u.

Via Sangano, 48  
10090 Trana - Torino - ITALY  
tel. +39-011-934.40.300  
fax +39-011-933.88.64  
e-mail: info@spacetest.com  
www.spacetest.com

A DOVER COMPANY

Le caratteristiche tecniche e gli allestimenti presentati in questo prospetto possono subire variazioni. Le immagini riprodotte non sono vincolanti.

Technical data and composition presented in this catalogue may vary.

Pictures reproduced are only indicative.

Die techn. Daten und die Ausrüstungen, die in diesem Prospekt enthalten sind, können Änderungen erfahren. Deshalb sind die Abbildungen unverbindlich.

Les caractéristiques techniques et les compositions présentées dans ce prospectus peuvent subir des variations. Les images reproduites n'ont qu'une valeur indicative.

Las características técnicas y las composiciones ilustradas en este folleto pueden sufrir variaciones. Las imágenes propuestas son solamente indicativas.

DTD10U (10)